

Main Applications

- Indication and alarm of melt temperature and pressure on extrusion lines.
- Test benches.
- Food processing plants: temperature and pressure indication.
- Weighing
- Pressure switches, thermostats
- Textile plants



Main features

- Inputs configurable from faceplate.
- Easy strain-gauge calibration with sensitivity auto-ranging.
- Control of sensor power supply (input 1).
- Selectable code protection.
- Possibility to configure the unit.
- Power supply for transmitters.
- Easy to configure. Custom linearization available.
- Engineering units of the most common physical quantities available either on display or on labels.
- Acquisition and alarm programmable from 15 up to 120 msec. with resolution from 16000 to 4000 divisions
- Retransmission of variable values
- 3 alarms completely configurable from faceplate.
- 4-wire, configurable serial line. Protocol: GEF 40 TB CENCAL or MODBUS

PROFILE

The 40 TB is a microprocessor based, 2-channel alarm unit, format 96x96 (1/4 DIN), manufactured with SMT. Its operator interface is comprehensive and efficient, with two 4-digit displays for the two process variables and engineering units indications. It is also equipped with a red LED bargraph, which can be associated to process variables and to peak values. Three LEDs indicate the output status, while 3 more LEDs can be configured to indicate different functional conditions. The instrument has a lexan membrane faceplate (guaranteed to IP65) with 4 keys.

Channel 1 has strain gauge, pressure or force sensor inputs, with positive or symmetrical polarisations, calibration with sensitivity auto-calculation (from 1,5 up to 4 mV/V), indication of probe power supply break.

The first input channel can also receive signals from potentiometers with 100Ω min. resistance. The A/D converter performance can be configured via keyboard, so that different options of sampling time can be selected, depending on the desired resolution. Sampling time can be as low as 15msec., while resolution can reach a max. value

of 16,000 divisions (by a 120msec. sampling time). The second input channel can be configured for inputs from temperature sensors (TC, RTD, PTC, NTC) and for mV, V, mA signals, with the ability to have of having a customized input for each kind of sensor.

The selection of the different options is available from keyboard. There is the possibility of having two digital inputs from voltage-free contacts, configurable for functions such as reset, hold, flash, peak or memory reset control.

The instruments can be equipped with up to three relay (5A/250V) or static (0-11Vdc) outputs.

Two voltage or current analogue outputs are available for the retransmission of inputs, of alarm sets, of gross and tare values. The serial communication option may have current loop, RS422/485 and RS232 connections with baud rate up to 19200.

The option "transmitter power supply" is foreseen for each input channel. For channel 1 it could be: 1V (potentiometer), 5 and 10V (strain-gauge), 15 and 24V; for channel 2: 15 and 24Vdc.

The programming of the instrument is made easy by grouping the parameters in function blocks and by a simplified data entry menu. The configuration can be

simplified even further using the PC programming kit containing connection cable and a menu guide program that runs under Windows (see technical data code WINSTRUM).

A configurable personal software protection code (password protection) can be used to restrict the levels of editing and displaying the configuration parameters.

TECHNICAL DATA

INPUTS

Accuracy 0.2% f.s. ± 1 digit.

- Input 1

Sampling time 120 msec. with control of sensor power supply, configurable down to a minimum of 15 msec. with reduction of the resolution to 4000 points. Configurable decimal point position for linear inputs, for strain gauge inputs or potentiometer range -1999...9999, indication of min. and Max. over-range for linear inputs. A 32-segment custom linearisation can be entered.
- 4/6 wire strain gauge 350Ω, sensitivity: 1.5...7.5mV/V by 10V power supply 1.5...15mV/V by 5V power supply.

Positive or symmetrical polarisation and calibration that automatically calculates the sensitivity.

- Potentiometer supply 1.2V >100Ω
- Current 0...20mA, 4...20mA, Ri= 50Ω.

- Input 2

Sampling time 120 msec. for temperature sensors, for linear inputs, configurable down to a minimum of 15 msec. with reduction of resolution to 4000 steps. Configurable decimal point position for linear inputs, for TC, RTD, PTC, NTC inputs only one decimal point is allowed in the maximum display range of -199.9...999.9.

Indication of open circuit thermocouple or RTD, PTC, NTC in open or short circuit, indication of over- and under-range for linear inputs.

TC – Thermocouple

Cold junction auto-compensation.

- J** (Fe-CuNi) 0...1000°C / 32...1832°F
- K** (NiCr-Ni) 0...1300°C / 32...2372°F
- R** (Pt13Rh-Pt) 0...1750°C / 32...3182°F
- S** (Pt10Rh-Pt) 0...1750°C / 32...3182°F
- T** (Cu-CuNi) -200...400°C / -328...752°F
- B** (Pt30Rh-Pt6Rh) 44...1800°C / 111...3272°F
- E** (NiCr-CuNi) -100...750°C / -148...1382°F
- N** (NiCrSi-NiSi) 0...1300°C / 32...2372°F
- (Ni-Ni18Mo)** 0...1100°C / 32...2012°F
- L-GOST** (NiCr-CuNi) 0...600°C / 32...1112°F
- U** () -200...400°C / -328...752°F
- G** () 0...2300°C / 32...4172°F
- D** () 0...2300°C / 32...4172°F
- C** () 0...2300°C / 32...4172°F
- Custom** -1999...9999

RTD 3 wires

- Pt100** -200...600°C / -328...1112°F
- JPt100** -200...600°C / -328...1112°F

PTC

- 990Ω 25°C
- 55...120°C / -67...248°F

NTC

- 1 KΩ 25°C
- 10...70°C / 14...158°F

DC – Linear

With scale configurable within the limits:
 -1999...9999 (4 digits)
 0...60mV / 12...60mV
 0...10V / 2...10V
 0...5V / 1...5V
 0...1V / 0.2...1V
 0...20mA / 4...20mA
 Input impedance for voltage signals
 Ri>500Ω for V ≤ 1V; Ri >20KΩ for V > 1V, for current signals: Ri = 50Ω.
 A 32-segment configurable linearisation can be used.

Digital

2 inputs from contact free of potential. The function is selectable among stored alarm reset, hold, flash, zero, selection of peak value (minimum, maximum, or peak-to-peak).

OUTPUT

Relay with NO(NC) contacts 5A, 250V cosφ=1. Three alarms configurable as output to calibrate 6-wire strain-gauge probes.

Analogue retransmission

- 1500V Isolation
- 2 configurable retransmission analogue outputs.
- Range configurable from keyboard.
- 0...10Vdc; 0/4...20mA configurable outputs.
- Resolution 4000 steps.

SERIAL LINK

4-wire, optoisolated. Passive current loop configurable interface (1200 bauds), RS232 and RS422/485 (1200, 2400, 4800, 9600, 19200 bauds) Protocol: GEFTRAN, CENCAL or MODBUS.

POWER SUPPLY

Standard: 100...240Vac/dc ±10%
 On demand: 20...27Vac/dc ±10%
 50/60Hz; 12VA max.
 Protected by an internal fuse (not replaceable by the operator).

SENSOR POWER SUPPLY (vs)

1.2Vdc for potentiometer > 100Ω
 5Vdc, 10Vdc max 120mA for strain-gauge
 Available for input 1 (Terminal 11).

TRANSMITTER POWER SUPPLY (vt)

24Vdc ±10% max. 50mA
 15Vdc ±10% max. 80mA
 Available for input 1 (Terminal 11) and input 2 (Terminal 3).

AMBIENT CONDITIONS

Working temperature range: 0...50°C
Storage temperature range: -20...70°C
Humidity: 20...85% HR non condensing

ALARMS

- 3 alarm points configurable as absolute, relative, with direct or inverse function.
- Alarm points with configurable limits on the whole selected scale.
- The hysteresis of each alarm is configurable individually.
- Alarm masking with exclusion on power up, with memory, delay and minimum alarm/intervention time.
- Alarms can be associated to single inputs, either as "OR" or "AND".

WEIGHT

Full version: 600g

FACEPLATE DESCRIPTION

- A** - Indication of input 1 variable, 13mm high digits, red LED display.
- B** - Indication of input 2 variable, 13mm high digits, red LED display.
- C** - "Function" key
- D** - "Lower" key
- E** - "Raise" key
- F** - Configurable function key (CAL standard)
- G** - Indication of CAL, ZERO, REM, red LED display
- H** - Indication of Out1, Out2, Out3 alarms, red LED display.
- I** - Label for engineering units

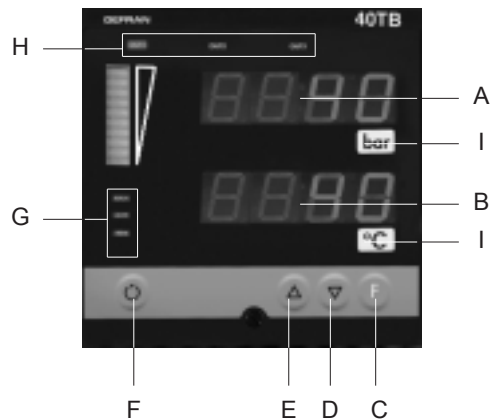

IP 65 faceplate protection

DIMENSIONS AND CUT-OUT

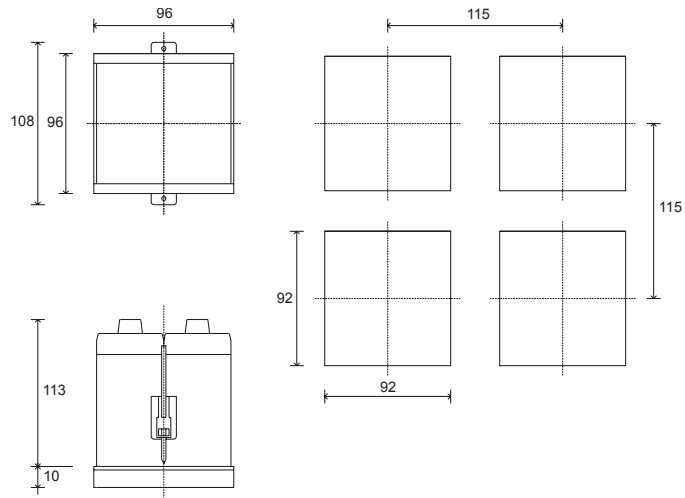

Dimensions 96x96 (1/4 DIN), depth 113 mm

CONNECTION DIAGRAM

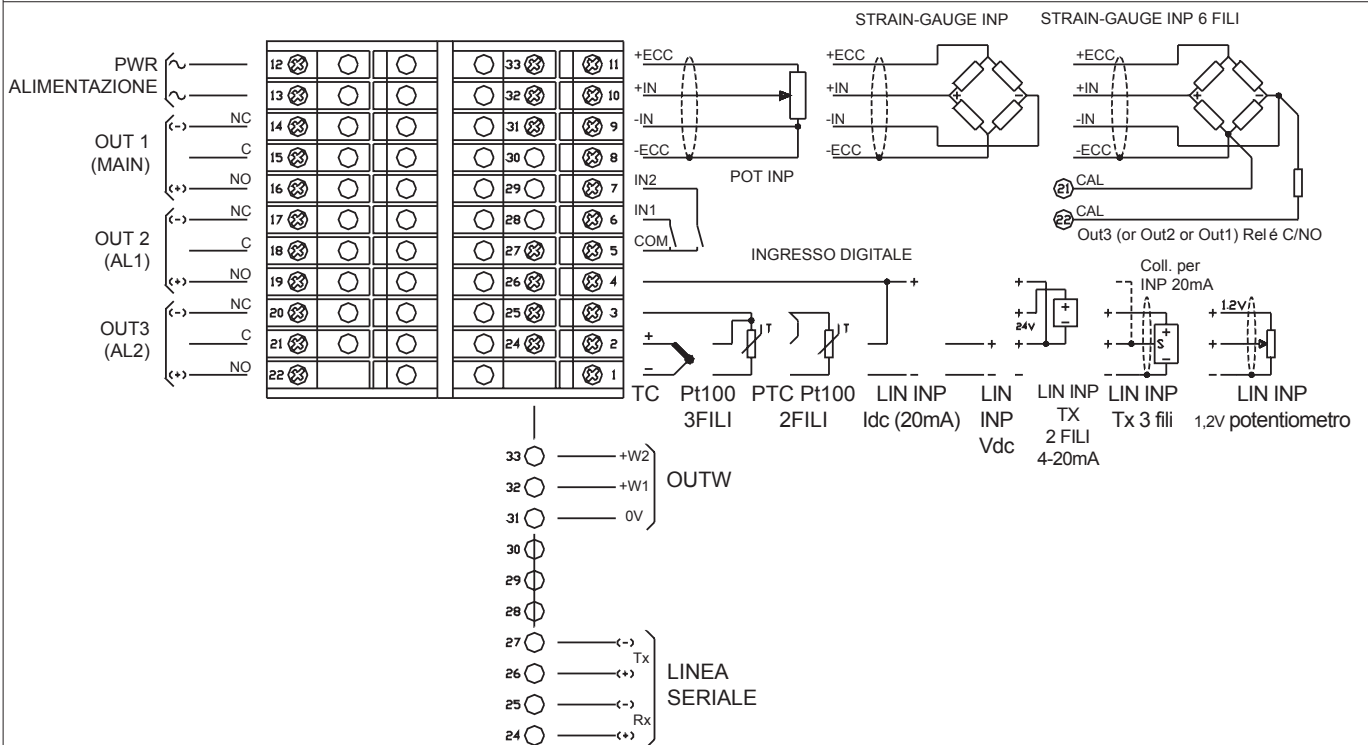

Follow user's manual mounting instruction to install the instruments properly.

ORDER CODE

40 TB R R R

SENSOR/TRANSMITTER POWER SUPPLY	
Sensor Power Supply (VS) input 1 only (Transmitter Power Supply VT not present)	
1,2Vdc (potentiometer)	0 1
5Vdc/120mA (strain-gauge)	0 5
10Vdc/120mA (strain-gauge)	1 0
Transmitter Power Supply (VT) for input 1 and input 2	
15Vdc/80mA (transmitter) (*)	1 5
24Vdc/50mA (transmitter) (*)	2 4

(*) Input 1 is configured for 4 ...20mA input



RETRANSMITTED OUTPUTS	
None	0
1 retransmitted output 0/4...20mA (0...10V)	1
2 retransmitted outputs 0/4...20mA (0...10V)	2

POWER SUPPLY	
0	20...27Vac/dc
1	100...240Vac/dc

DIGITAL COMMUNICATION	
0	None
2	RS 485 / RS232C

Please, contact GEFRAN sales people for the codes availability .

GEFRAN spa reserves the right to make any modification of the design or function, at any moment without prior notice.

	Conformity C/UL/US File no. E216851
	The instrument conforms to the European Directives 2004/108/CE and 2006/95/CE with reference to the generic standards: EN 61000-6-2 (immunity in industrial environment) EN 61000-6-3 (emission in residential environment) EN 61010-1 (safety)